

Packaging Specification for DFN0603 / DFN1006 / DFN1608

1. The method of packaging and dimension are shown as below figure. (Dimension in mm)

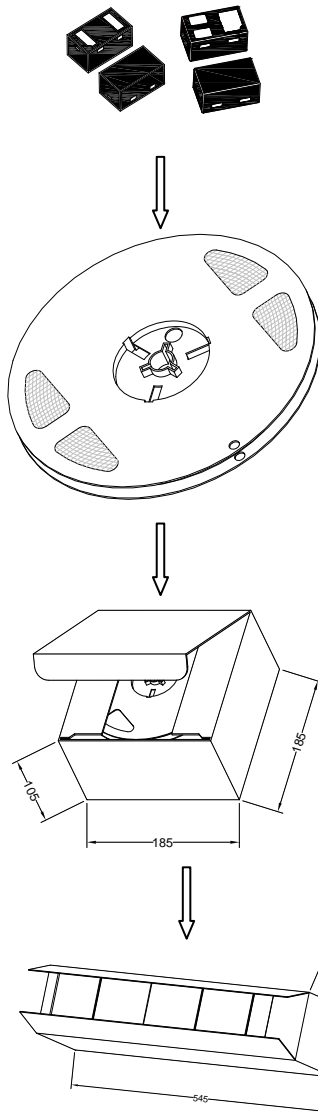

DFN0603
DFN1006
DFN1608

DFN0603: 10,000 pcs per reel
DFN1006: 5,000 pcs per reel
DFN1608: 4,000 pcs per reel

DFN0603: 80,000 pcs per box
DFN1006: 40,000 pcs per box
DFN1608: 32,000 pcs per box
8 reels per box

DFN0603: 400,000 pcs per carton
DFN1006: 200,000 pcs per carton
DFN1608: 160,000 pcs per carton
5 boxes per carton

2. Label

2.1 The information of inner box label must be listed: (Description of a sample lable)

- 2.1.1 TYPE **ESDUL2501BP-HAF** means (Product) TYPE (Part No.)
- 2.1.2 QTY **5,000 PCS** means (Product) Quantity (QTY)
- 2.1.3 **DIC SL0C2N0303T01** means Dice Lot No. / Code (D/C)
- 2.1.4 **PIC DDFE30006-J100001** means Production Code (P/C)
- 2.1.5 **RMK40307 25** means Manufacturing Date (RMK)

2.2 The information of carton label must be listed:

- 2.2.1 TYPE
- 2.2.2 QTY

TOP DYNAMIC



ISO14001 : 2004 Certificate No. 121505007
ISO 9001 : 2008 Certificate No. 50114012
OHSAS 18001 : 2007 Certificate No. 05131500006
IECQ QC 080000 Certificate No. EC311002714802

Dated: 15/09/2015 Rev: 02